

SHARP

MX-M950/MX-M1100

Black & White Production Systems

A Whole New Performance Benchmark

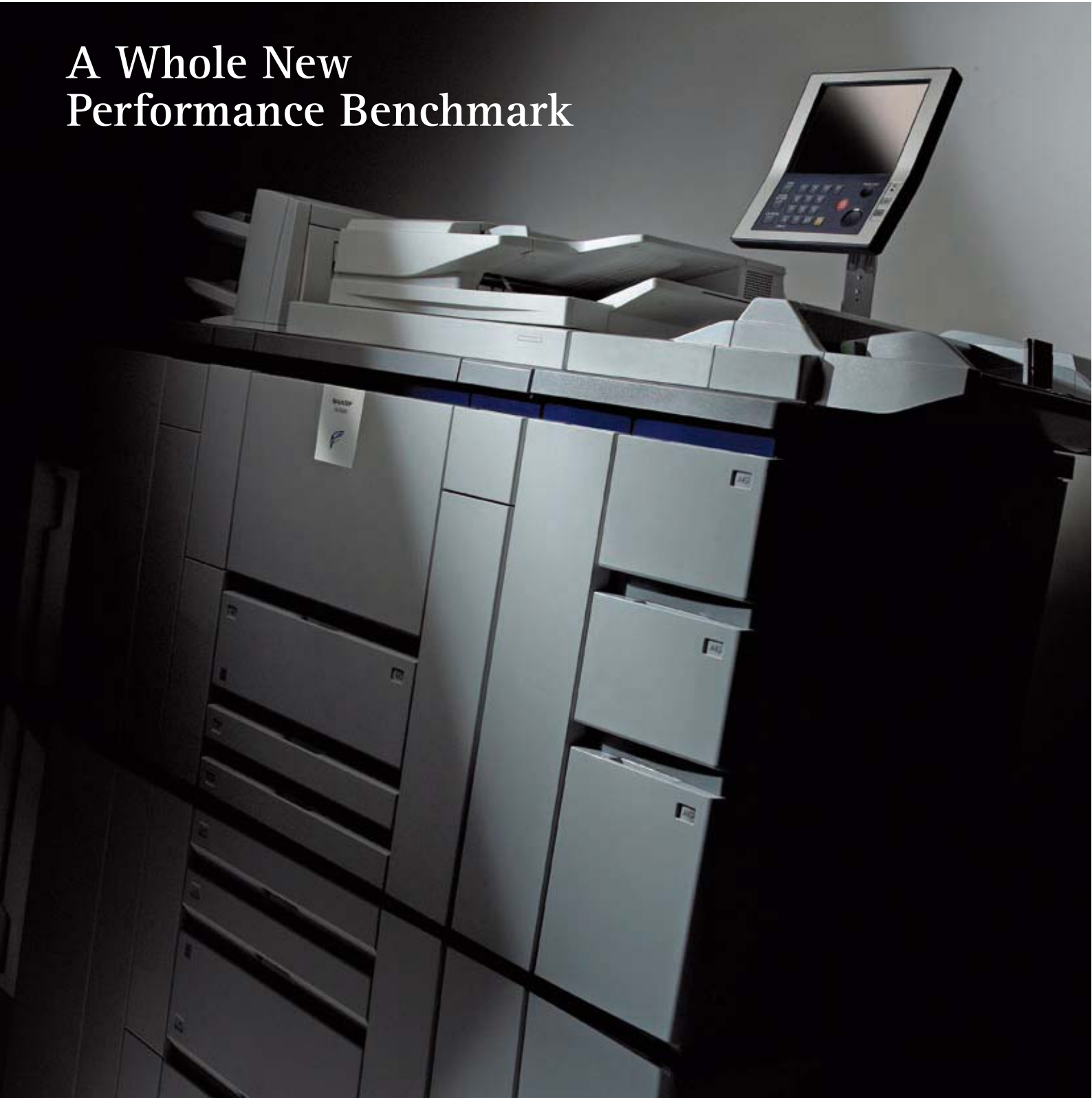

COPY

NETWORK PRINT
OPTION

NETWORK SCAN
OPTION

SHARPDESK
OPTION

FAX
OPTION

HIGHER RELIABILITY, HIGHER PRODUCTIVITY



It's time to let an MX-M950 or MX-M1100 handle your document needs with the reliability, durability, and productivity you can expect from Sharp. In high-volume environments like Centralised Printing Departments, these top-of-the-line document systems will provide new capabilities for the customer as well as opportunities for business growth. The MX-M950/MX-M1100 are versatile enough to help you meet crucial deadlines on a wide variety of document jobs at your performance-driven, time-challenged workplace. Therefore, when all eyes are on the clock, get down to business with an MX-M950/MX-M1100.

PHILOSOPHY

RELIABILITY, DURABILITY

COUNT ON SHARP'S AWARD-WINNING HISTORY

As history offers an insight into the future, then you can be assured that when you invest in one of the new Sharp MX-M950/MX-M1100 MFPs, you will be choosing the proven Sharp heritage of document imaging. Independent industry authorities such as Buyer's Laboratory, Inc., Better Buys for Business, Inc., and BERTL have consistently recognised the superlative achievements that set Sharp ahead of the competition. Prestigious awards including Product Line of the Year, Best Security Solution, Innovation Award, IT Friendliness, and Editors' Choice are all part of Sharp's illustrious history. The MX-M950 and MX-M1100 carry on this winning tradition with the Pick of the Year 2007 award.



NEW DESIGN, NEW LEVELS OF CUSTOMER SATISFACTION

What Every Business Needs

Sharp not only recognised the need for fundamental product characteristics such as reliability and durability but also understood where these MFPs would be positioned in the marketplace. This vision is what made the MX-M950/MX-M1100 document systems ideal for government institutions and large enterprises, where cost and time are crucial. Additionally, these devices are an excellent fit in legal, financial, and medical markets where data security and confidentiality are required.

Determined to create next-generation Sharp document systems that deliver the utmost in customer satisfaction, Sharp market planning, research, and development teams came up with a totally new design for the MX-M950/MX-M1100. As a result, these latest additions to Sharp's black-and-white production family have precisely what it takes to meet both private and public sector demands. Unrivalled versatility, best-in-class paper support, fast input, high-volume output, a wide range of finishing options, and easy maintenance make the MX-M950/MX-M1100 perfect for large enterprises and in-plant printing facilities. Tough, multi-layered security makes them ideal for financial, legal, medical, and other organisations where confidentiality is crucial. Additionally, low running costs and flexible configuration make the MX-M950/MX-M1100 an equally good choice for government and academic institutions.

- The Sharp MX-M950/MX-M1100 document systems have been engineered and built from the ground up to handle the rigid demands of production environments, easily producing hundreds of thousands of pages per month.
- Reliability, durability, and productivity were key components in Sharp's engineering philosophy and design specifications when developing these high-volume workhorses. With new standards, new markets, and new benchmarks, these high-speed monochrome document systems fit perfectly into Centralised Printing Departments, corporate offices, and the most challenging high-volume environments.
- Each MX-M950/MX-M1100 document system can be customised with a variety of options to create a unique solution for every challenging production setting. Whether you choose the mid-range 95-ppm alternative, or the powerful 110-ppm system, you can be assured that Sharp can configure a system that's right for any environment.



PRECISION ENGINEERING

HIGH PERFORMANCE

From conception to execution, the goal in any production environment is performance. That is why Sharp engineered breakthrough performance features into the MX-M950/MX-M1100—precision design characteristics you cannot see but will certainly appreciate in daily use.

SUPERIOR PAPER SUPPORT

Among the best in class by virtually all measures, the support includes an eight-way paper supply and a paper capacity of up to 8,050 sheets.

HIGH-VISIBILITY CONTROL PANEL

The 10.4-inch colour LCD touch-screen display, with a job status lamp that is easily visible from across the room, helps you intuitively navigate any job.

FAST PRINT PERFORMANCE

A high-performance RISC processor draws maximum performance from the printer engine to achieve an amazing 110 prints per minute on A4-size paper. The MX-M950 at 95 ppm also deliver high-speed print performance.

ADVANCED SCANNING CAPABILITY

Sharp's large-capacity Duplex Single Pass Feeder (DSPF) with duplex scanning technology scans two-sided documents in a single pass. For maximum productivity and minimal paper handling, Sharp's DSPF can handle up to 250 sheets at an impressively fast scanning speed of 120 opm for the MX-M950/MX-M1100.

STANDARD NETWORK INTERFACE

These powerful machines are fully network-ready and offer Web-based device management for easy configuration and set-up.

QUIET OPERATION

Precision engineering for proven durability and surprisingly quiet operation make them easy to own and work with.

EASY SERVICEABILITY

Full front access to all key machine components ensures easy maintenance and thus maximum uptime. The durable organic photoconductor drum (OPC) has a long service life of up to one million copies. Since 500,000 copies can be made before periodical maintenance is required, machine downtime is reduced.

*First print out time based on A4-size paper.

ENGINEERED FOR RELIABILITY

Developer Cooling Systems

The MX-M950/MX-M1100's forced-air cooling system for the developer unit helps prevent excessive heat build-up to keep image quality stable even in high-volume environments.



Multi-Feed Detection Sensor (MX-M950, MX-M1100)

The precision engineering design of the Sharp Multi-Feed Detection System employs ultrasonic technology to help diagnose and detect misfeeds from the document feeder as well as from the paper feed section of the paper trays.

Independently Driven Units

Independent motor units are employed for essential functions of the MX-M950/MX-M1100, such as the paper pick-up unit and the paper transfer unit. This design improvement provides highly reliable operation and helps ensure dependable paper transportation throughout each reprographic cycle, increasing durability for the long run.

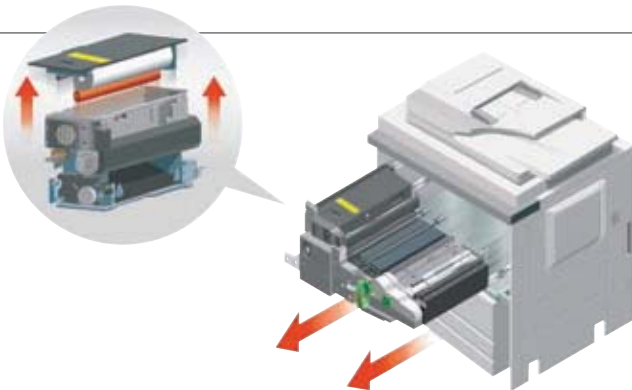

Slide-Out Components for Easy Maintenance

This design makes service and general maintenance of the MX-M950/MX-M1100 easier by allowing technicians to slide out main units to adjust or exchange sub-components, thus eliminating the need to disassemble the entire machine.

Highly Rigid Main Frame

For increased reliability and durability, a newly developed, highly rigid frame better protects and isolates critical machine components. It also ensures that the MX-M950/MX-M1100 can withstand heavy use from high-speed, high-volume output.



FLEXIBILITY AND VERSATILITY

The flexibility to configure a production document system for a variety of applications and the versatility of that system in accommodating a wide base of users are both key to successful implementation in the workplace. Sharp's MX-M950/MX-M1100 document systems excel in allowing users to customise hardware and software configurations – from paper input and document management to finished output. For added versatility, businesses can opt for powerful network printing that offers point-and-click simplicity.

PERFORMANCE

BREAKTHROUGH

FEATURES THAT KEEP YOUR BUSINESS MOVING

The MX-M950/MX-M1100 document systems come with 1.28GB of standard memory, making them the productivity hubs of busy workgroups. An 80-GB HDD ensures robust processing power for large, complex jobs.

- MX-M950/MX-M1100 document systems can copy and print on a weight index of up to 300 g/m², so a variety of documents can be produced in-house.
- The security-enabled network interface card provides highly secure operation by restricting access to the MX-M950/MX-M1100 on your office network. Only PCs that have their IP address and/or their MAC (media access control) address registered can gain access to the MX-M950/MX-M1100. Attempted access from an unknown IP or MAC address will be denied, preventing unauthorised use.
- Versatile application integration with Sharp OSA technology enables users to access network applications right from the LCD panel.

A FLEXIBLE DESIGN TO MEET THE DEMANDS OF YOUR UNIQUE ENVIRONMENT

Designed for high-volume production environments, the new MX-M950/MX-M1100 document systems deliver lightning-fast output with robust multi-tasking performance, so your workflow never misses a beat. It accommodates a weight index of up to 300 g/m², making it easier than ever to produce a variety of documents in-house. With a standard paper capacity of 3,000 sheets (expandable to 8,050 sheets), these productivity-boosting MFPs can manage large-scale jobs with incredible efficiency. Thus, combining the flexible paper handling system with a wide range of options allows these powerful performers to meet the needs of any high-volume production environment. For large copy or print jobs, choose from either the optional 4,550-sheet A4-size Large Capacity Tray (MX-LCX4) or the 4,000-sheet A3-size Large Capacity Tray (MX-LCX5). For even more flexibility, add the optional 500-sheet auto-bypass tray.

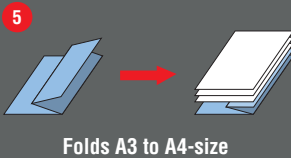

1. **4,000-Sheet, 3-Drawer, A3-Size Large-Capacity Tray** provides greater paper capacity for uninterrupted runs of high-volume jobs.
2. **Standard 250-sheet Duplex Single Pass Feeder** scans both sides of documents at the rate of 120 pages per minute.
3. **Main Unit** can be configured with a variety of input and output hardware options, as well as software options that include network colour scanning, network printing, Super G3 faxing, and more.
4. **Inserter** adds pre-printed covers and inserts to your documents for professional-looking results.
5. **Z-Folding Unit** automatically folds pages to accommodate professional document distribution.
6. **Saddle Unit** can centre-staple documents to create professional-looking booklets.
7. **Stapler Finisher** for applications of up to 100 sheets.
8. **Manual Finishing Off-Line Mode*** allows jobs such as sheet insertion, stapling, and Z-folding to be completed even when the machine is not printing.

* Inserter is needed for this mode.

MAXIMISE EFFICIENCY AND PRODUCTIVITY

EXPANDED CAPABILITIES FROM START TO FINISH

Powerful MFPs for multitasking and productivity

Built for high volume, the new MX-M950/MX-M1100 boast impressive B/W speeds of 95 and 110 ppm, respectively. The series also features an 80GB hard drive with 1.28GB of standard memory to help even the busiest enterprises manage document workflow and process jobs faster.

High-efficiency scanning

For optimum productivity, the new MX-M950/MX-M1100 document systems offer Sharp's award-winning **duplex scanning technology**. This innovative technology utilises dual scan heads to simultaneously scan both sides of a document in a single pass, minimising paper misfeeds and improving reliability. Additionally, with Sharp's newly designed **250-Sheet Duplex Single Pass Document Feeder (DSPF)**, documents are scanned at up to 120 images per minute on the MX-M950 and MX-M1100, so even large projects can be completed quickly.

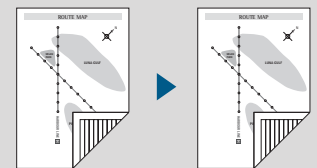

INNOVATION

FEATURE

True multi-tasking with dual processing

The new MX-M950/MX-M1100 document systems feature a 64-bit, multi-tasking controller that delivers copy, fax, and print jobs continuously for optimum efficiency. Other controllers perform only one operation at a time, but the MX-M950/MX-M1100 controller continually processes incoming jobs even while existing jobs are being output. The result? A workflow that never slows down!

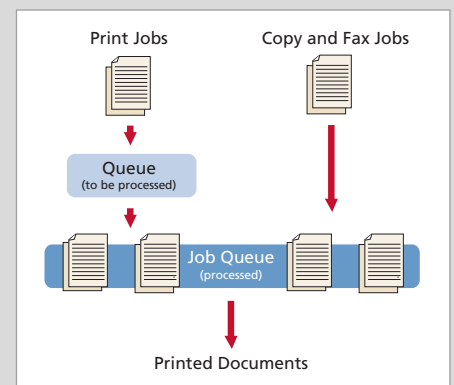

Productive, professional finishing options

These new MFPs offer a variety of finishing options including a saddle unit, a z-folding unit, and an inserter. For extremely large jobs, these models offer the option of a customisable paper supply capacity of up to eight online paper sources with an 8,050-sheet capacity for minimum interruption.

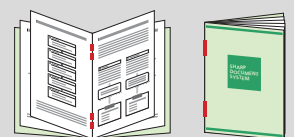

DOCUMENT WORKFLOW & DISTRIBUTION

STREAMLINE YOUR WORKFLOW WITH ADVANCED DISTRIBUTION FEATURES



With easy-to-use options, scanned images can be sent or forwarded to network destinations.



LDAP screen

Integrated network scanning

With Sharp's powerful **ImageSEND technology**, you get one-touch distribution features that centralise document workflow, help reduce mailing costs, and save time. With up to seven destinations—E-Mail, Desktop, FTP, Network Folder (SMB), USB, Fax, and Internet Fax—simultaneously sending your document out to different destinations is as easy as pushing a button. The Send to Group mode allows mixed-group broadcasting to all seven destinations for increased efficiency.*

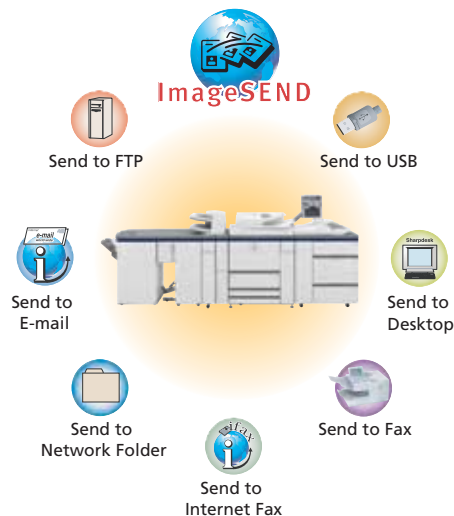

Convenient and e-mail distribution

With **LDAP**, there's no need to manually enter a recipient's complete e-mail address. Simply enter the first few characters and the MX-M950/MX-M1100 document systems automatically search and display a list of matching names. Plus, with the Unique File Naming feature, you can enter specific file names with custom subject fields, making it easier to recall files when you need them.

Scan documents in full colour

With the optional **Colour Expansion Kit**, users can scan documents to E-Mail, Network Folders and other select destinations in full colour. This innovative feature allows your business to easily share hard-copy colour documents, such as brochures, newsletters, quarterly reports, invoices, and more.

Convenient USB support

The MX-M950/MX-M1100 also support popular USB memory devices for today's on-the-go professionals. Scan files directly to a USB device, or simply plug in and print directly without creating network traffic. Most popular industry-standard file formats are supported, including TIFF, JPEG, PDF, and Encrypted PDF.*



Powerful Super G3 faxing

The optional **Super G3 Fax Kit** delivers lightning-fast faxing for busy workgroups. Integrated PC Fxing allows you to fax a document directly from your desktop. Additionally, with the help of the optional Stapler Finisher, incoming faxes can be collated, stapled, and/or copied for distribution, saving you time. **Inbound Routing*** lets you set parameters so that faxes can be sent directly to your e-mail address, allowing on-the-go users to check on incoming orders, to purchase orders, and more. Settings can be easily managed through the user-friendly Web page. For additional savings, the optional **Internet Fax Expansion Kit** can help reduce long-distance phone costs.

*Some features require optionally available equipment.



IMAGINE THE POSSIBILITIES GET MORE OUT OF YOUR BUSINESS APPLICATIONS

Sharp OSA technology at a glance

- Automates tasks and saves time by providing seamless integration between the MX-M950/MX-M1100 and network applications
- Centralised applications minimise set-up and installation on multiple Sharp products
- Virtually eliminates repetitive tasks and streamlines workflow for increased efficiency
- Maximises your return on investment through tighter integration of IT assets
- Industry standard programming leads to faster deployment of new solutions

The MX-M950/MX-M1100 document systems immediately give your business powerful functionality to leverage previous investments in data management infrastructure—right from the MX-M950/MX-M1100 control panel. Sharp's newest innovation, the Sharp OSA development platform, pioneers a new “power at the panel” approach to automating tasks and streamlining workflow.

Since Sharp OSA provides seamless integration between your MFPs and network applications, you will save time and increase the efficiency of everyday tasks. Any MX-M950/MX-M1100 anywhere in the organisation can display choices that were once only available on a desktop PC. With one-touch access to business applications via Sharp OSA integration, you can start and finish a document distribution task without worry.

The Sharp OSA development platform is the logical choice to complement your existing infrastructure because it transforms the MX-M950/MX-M1100 into a gateway to fast, flexible access to documents and applications no matter where you are in the office. You also get the controlled access and tracking capability you require, with tighter integration

SCALABILITY

VERSATILE

for network security and accounting applications. With such comprehensive control, you will be able to manage your document workflow easily, efficiently, and more securely.

Sharp OSA technology also opens the door to timesaving, productivity-boosting customisation. By allowing you to personalise applications and processes specific to your business, Sharp OSA technology helps eliminate redundancy and streamline workflow. Additionally, since Sharp OSA technology utilises industry-standard network protocols, such as SOAP, XML, and XHTML, third-party software developers can deliver customised solutions to your business faster than ever.



Dual Communication Channels

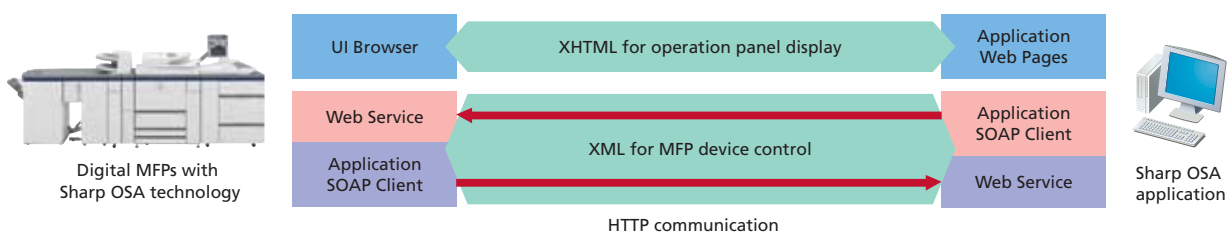

SAFEGUARD YOUR COMMUNICATIONS

ADVANCED DOCUMENT SECURITY PROTECTS YOUR ASSETS

MX-M950/MX-M1100 document systems feature several layers of security that protect your data, making Sharp the optimum choice for the protection of employee privacy and intellectual property. As a leader in office equipment security, Sharp makes it easy for any business or government entity to safely deploy digital copying, printing, scanning, Internet faxing, and faxing.



Outstanding MFP Security Solution

Account codes

Account management enables administrators to control access functions (Copy, Scan, Internet Fax, Fax, and Print) and to monitor usage.

Security at your fingertips

Get the control and security you need to minimise risk in today's changing office environment. The MX-M950/MX-M1100 document systems support LDAP with integrated User Authentication. This allows workgroups to regulate access to features and functions, providing unprecedented control over usage and costs. Three levels of access protect sensitive documents from being scanned, faxed, or e-mailed, so your data is never compromised.

Document protection

To protect your printed documents from unauthorised viewing, the MX-M950/MX-M1100 document systems support IPP-SSL protocol, and offer confidential printing that requires users to enter a PIN code in order to print a document in the queue.

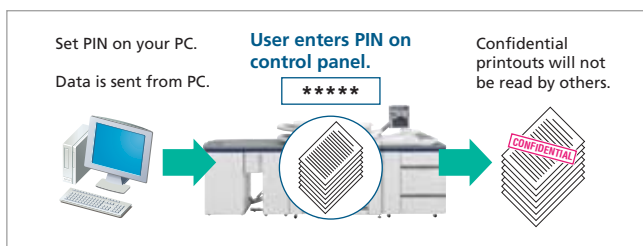

Network scanning access

To protect your network from unauthorised e-mail communications, the MX-M950/MX-M1100 support IPP-SSL, SMTP-SSL, FTPS, and User Authentication, requiring users to log in before performing any network scanning operations.

Tracking and auditing information

Legislative and industry policies require companies to be aware of information flow. Sharp offers both built-in and additional hardware/software that allows users to control, access, and track usage of each MFP on the network. These scalable security offerings protect intellectual property, preserve confidential information, and help your business meet regulatory requirements.

Data encryption and erase

To better protect your data, the MX-M950/MX-M1100 document systems offer an optional Data Security Kit that encrypts document data. Additionally, the Data Security Kit erases the temporary memory on the hard drive by overwriting encrypted data up to seven times, providing an unprecedented level of assurance.

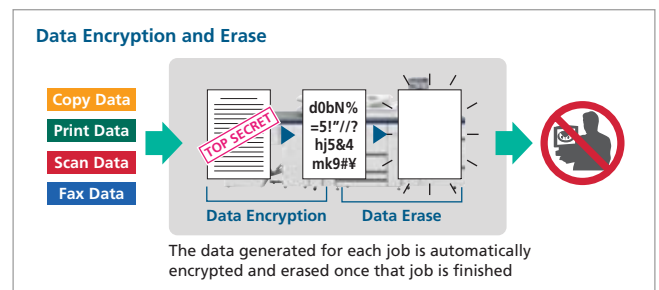

IP/MAC address filtering

To prevent unauthorised use of the MX-M950/MX-M1100 over the network, IP/MAC address filtering grants access only to PCs that have registered IP or MAC addresses and blocks access attempts from unknown addresses. Protocol enable/disable and port management also help maximise security.

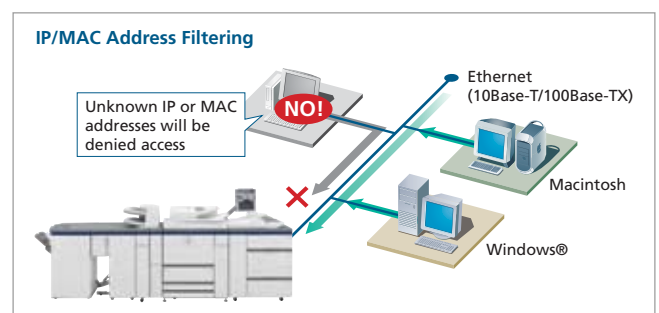

Additional network security

To help restrict access to the MFP over the network, the MX-M950/MX-M1100 document systems offer:

- Secure Socket Layer (SSL Encryption)
- IPv6 and IPsec
- IP/MAC address filtering, protocol enable/disable, and port management for maximum security



Search screen

* Image Compression Tool for converting images into high-compression PDF files

Sharpdesk desktop document management software helps users organise, annotate, edit, and combine files prior to distribution.

INTEGRATED, USER-FRIENDLY SOFTWARE MANAGE DOCUMENT WORKFLOW

Managing digital workflow has never been easier — and more seamless

Powerful, flexible, and intuitive, Sharpdesk software enables you to easily integrate scanned documents into your everyday workflow. Easy-to-use tools help you organise, edit, and even combine scanned files for maximum productivity. The Search and Index feature provides sophisticated tools that enable you to retrieve archived Sharpdesk documents with incredible ease.

Sharpdesk is an original Sharp application that provides integrated desktop management of documents in over 200 file formats, including scanned paper-based documents and those created with popular applications such as Word. It allows you to organise, edit, search, and distribute your documents, all with simple drag-and-drop operation.

- Intuitive desktop display features **thumbnail** viewing
- Sharpdesk Imaging provides **annotation** tools for paper-free proofreading
- Sharpdesk **Composer** combines different types of files into a single document
- **Optical character recognition** converts documents into editable text files
- **Output zone** distributes files to e-mail, printers and other applications
- **File search** allows searching by file name, keyword or thumbnail

DOCUMENT MANAGEMENT



Printer Administration Utility

Integrated Web-based Device Management

Administrators can set up many features either from over the network or from the control panel of the MX-M950/MX-M1100, including address book control, document filing management, user control (accounting) and e-mail alert and status settings.

Printer Administration Utility makes printer networks easier to manage by allowing network administrators to customise monitored items and view settings such as the IP address directly from their PC through a standard Web browser.

Standard Print/Copy/Scan Tracking

The versatility of MX-M950/MX-M1100 document systems makes them one of the most widely used devices in the workplace. To monitor and track all of this activity, Sharp includes standard copy/print accounting controls. The Print/Copy/Scan Auditor enables administrators and IT managers to track usage by ID number (up to 1000 accounts) as well as by PIN code authorisation.

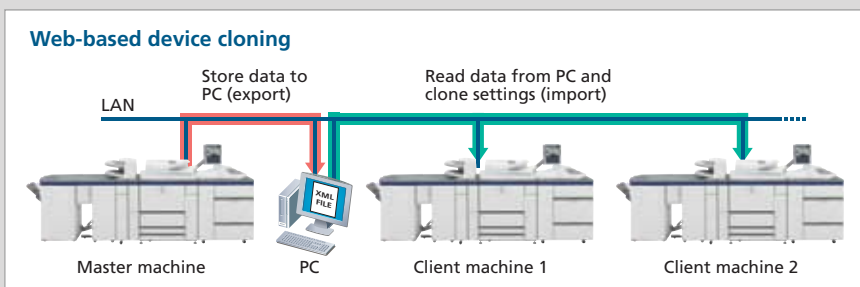

Device Cloning

Machine settings can be conveniently copied to another MX-M850/MX-M950/MX-M1100 via a Web browser or USB device, making it easy to clone machines in a networked environment.



Document Filing makes it easy to find and retrieve forms and templates and to receive and save new documents.

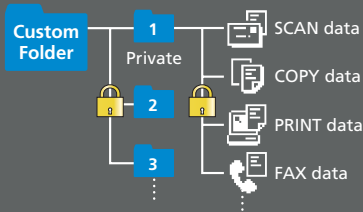
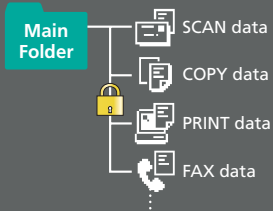
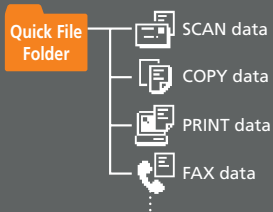

Increase efficiency with document filing

For even more efficiency, the MX-M950/MX-M1100 document systems offer convenient Document Filing. With this on-board storage/retrieval system, users can store frequently used files such as copy jobs, print jobs, forms, and more. Moreover, with the Colour Expansion Kit, documents can be scanned and saved in full colour. The Document Filing System comes standard with 40GB of document storage capacity, so everyone can easily store, retrieve, and route saved documents.

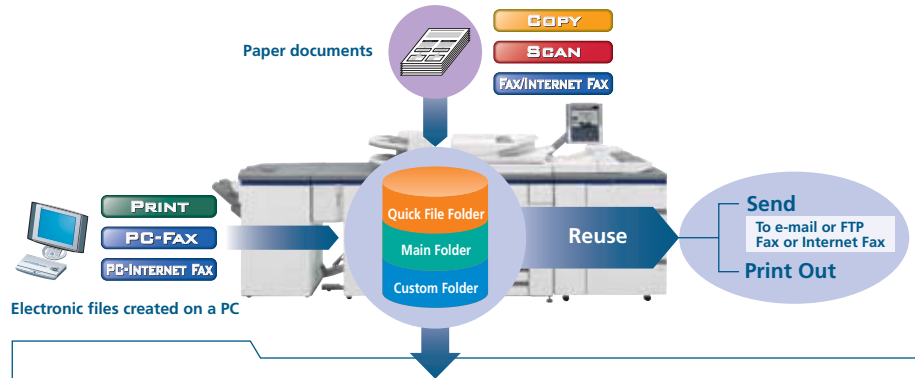

Quick Filing with Temporary Storage

Save up to 14,000 pages or 1,000 files*¹ of processed copy, print, scan and fax*² job data in Quick File Folders on the hard disk for later use, eliminating the need to recreate jobs.

Advanced Filing for Long-Term Storage

Save job data on the hard disk in up to 500 folders with customised names and locations and with enhanced security features to protect your sensitive data. You can store up to 45,000 pages or 3,000 files*¹.

Storage options include:

- Main Folder – You can store processed files by user name in a central location for convenient workgroup sharing. Any file name and a PIN code can be assigned to each job.
- Custom Folder – You can save confidential files in up to 500 private folders created with a desired name. A PIN code can be applied to both private folders and files.

*1: Measured using Sharp's standard chart (A4 with 6% coverage, black & white). The Quick File Folder shares the hard disk with the Job Build function. The storage capacity will be less for colour pages.

*2: For fax and Internet fax jobs, only transmitted data (not received faxes) can be saved in the Document Filing function.

USER-FRIENDLY FEATURES

Easy-to-use touch-screen display

The MX-M950/MX-M1100 document systems utilise a large 10.4-inch touch-screen colour display, which offers large, easy-to-read text and icon-driven graphics as well as easy-to-see intuitive menus that can be navigated with ease. It provides users with intuitive menus for every machine function—from copy and scanning input to final finishing—as well as comprehensive diagnostics for easier maintenance. This unique display features an Intuitive User Interface that allows the touch screen to display shortcut keys that can be programmed to provide instant access to the features your business uses most often.

Intuitive user interface

Everyone, from the casual walk-up user to the mailroom production staff, will find it easier to get the job done from start to finish with the easy-to-understand and easy-to-use graphic user interface on the touch-screen LCD panel.

Job status lamp

High-visibility red and green job status lights allow users to monitor a print or copy job from start to finish, even from across the room.

SYSTEM CONFIGURATION

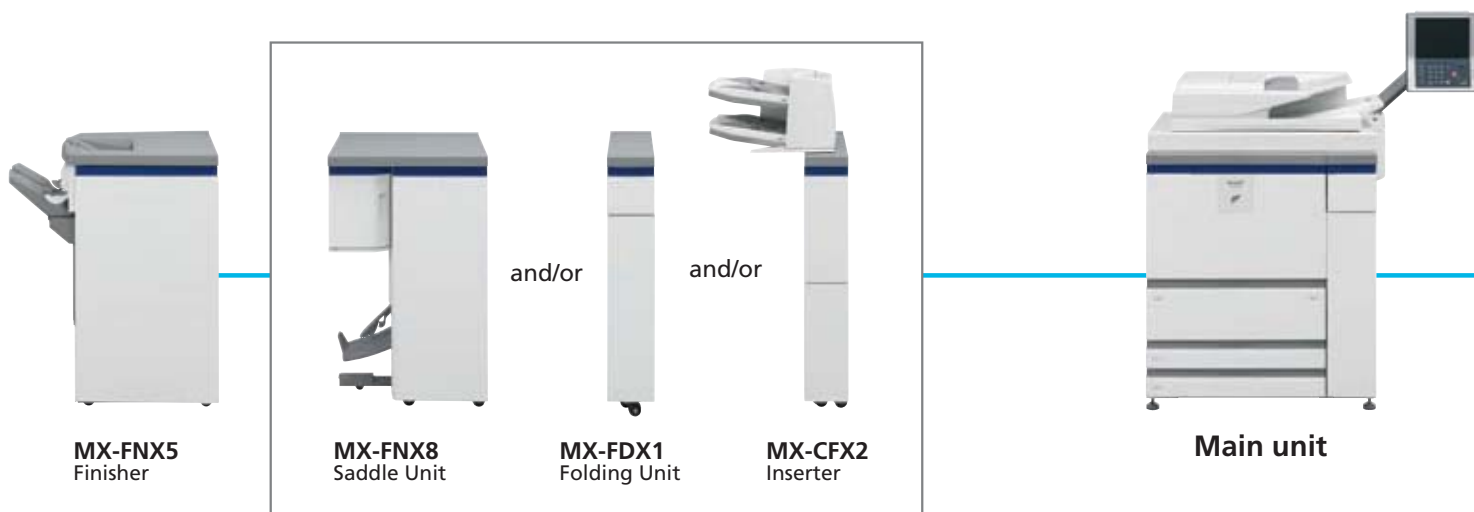

SPECIFICATIONS OF OPTIONS

MX-FNX5 Finisher

Paper size	Non offset & Offset Staple	A3 wide to A5R SRA3 (320 x 450 mm) A3 to B5R
Max. paper capacity (80 g/m ²)		3,000 sheets (A4)
Max. stapling capacity		100 sheets (A4)
Staple position		4 locations (top, top slant, bottom, 2 staples)
Paper weight (Stitched)		60–105 g/m ²
Stored paper weight (Non stitched)	Non offset Offset	52–205 g/m ² 52–300 g/m ²

MX-CFX2 Inserter

Paper size	A3 wide to A5R
Paper capacity (80 g/m ²)	Upper tray: 200 sheets Lower tray: 200 sheets
Paper weight	60–205 g/m ²

MX-FNX8 Saddle Unit

Paper size	A3 wide to B5R (Saddle section)
Paper capacity	2 to 5 sheets staple (30 bundles) 6 to 10 sheets staple (15 bundles) 11 to 15 sheets staple (10 bundles)
Paper weight	60–90 g/m ² cover up to 176 g/m ²

MX-LCX4 Large Capacity Tray

Paper size	A4 to A5R and A4 wide (228.5 x 305 mm)
Paper capacity (80 g/m ²)	Upper tray / middle tray: 1,000 sheets Lower tray: 2,550 sheets
Paper weight	Upper tray / middle tray: 52–205 g/m ² Lower tray: 52–163 g/m ²



When installing MX-MFX2, you must install either MX-LCX4 or MX-LCX5. However, when installing either MX-LCX4 or MX-LCX5, MX-MFX2 is optional.



MX-MFX2
Multi Bypass Tray



MX-MFX1
Multi Bypass Tray



MX-LCX6
Large Capacity
Tray (A4)

When installing MX-MFX1,
you must install MX-LCX6.

- MX-PNX3A/B/C/D**
Punch Module [for MX-FNX5]
- MX-PBX2**
Printer Expansion Kit
- MX-PEX3**
Fiery Printer Controller
- MX-PXX3**
Interface Kit for MX-PEX3
- MX-PKX4**
PS3 Expansion Kit
- AR-PF1**
Barcode Font Kit
- MX-FWX1**
Internet FAX Expansion Kit
- MX-NSX1**
Network Scanner Expansion Kit
- MX-EBX1**
Colour Expansion Kit
- MX-FXX1**
Facsimile Expansion Kit
- MX-USX1**
Sharpdesk 1 License Kit
- MX-USX5**
Sharpdesk 5 License Kit
- MX-US10**
Sharpdesk 10 License Kit
- MX-US50**
Sharpdesk 50 License Kit
- MX-USAO**
Sharpdesk 100 License Kit
- MX-AMX1**
Application Integration Module Kit
- MX-AMX2**
Application Communication Module
- MX-AMX3**
External Account Module
- MX-FRX8U**
Data Security Kit
- MX-FRX8**
Data Security Kit
(Common Criteria validated)
- AR-SU1**
Stamp Unit

MX-LCX5 Large Capacity Tray

Paper size	Auto Manual	A3 wide to A5R Max. SRA3 (320 x 450 mm)
Paper capacity (80 g/m ²)		Upper tray / lower tray: 1,000 sheets Middle tray: 2,000 sheets
Paper weight		Upper tray / lower tray: 52–205 g/m ² Middle tray: 52–300 g/m ²

MX-LCX6 Large Capacity Tray

Paper size	Max. A4
Paper capacity (80 g/m ²)	3,500 sheets
Paper weight	60–205 g/m ²

MX-FDX1 Folding Unit

Folding type	Z-folding
Paper size	A3 to A4R
Paper weight	60–90 g/m ²

MX-MFX1 Multi Bypass Tray (for MX-LCX6)

Paper capacity (80 g/m ²)	100 sheets
Paper size	A3 wide to A5R
Paper weight	52–300 g/m ²

MX-MFX2 Multi Bypass Tray (for MX-LCX4 and MX-LCX5)

Paper capacity (80 g/m ²)	500 sheets
Paper size	Auto feed: A3 wide to A5R Manual feed: Max. SRA3 (320 x 450 mm)
Paper weight	52–205 g/m ²

Sharpdesk 3.2 System Requirements

CPU	Pentium 500MHz processor or better (750MHz or better for Windows® XP)
Memory	256MB or more (512MB or more recommended)
Hard disk	300MB or more available space (including sample image files and help files)
Monitor	SVGA resolution or better and capable of displaying more than 256 colours (True Color recommended)
Supported OS	Windows® 98 Second Edition, Windows® Me, Windows® 2000 Professional, Windows® XP Professional, Windows® XP Home Edition, Windows® Vista
Network protocols	TCP/IP (using Network Scanner Tool)

SPECIFICATIONS

General

Type	Console
Engine speed ¹	Max. 95 cpm/ppm (MX-M950) Max. 110 cpm/ppm (MX-M1100)
Original paper size	Max. A3W, min. A5R
Paper size	Tray 1: A4, B5 Tray 2: A4 Tray 3: Max. A3W, min. B5R Tray 4: Max. A3W, min. A5R
Paper capacity (80 g/m ²)	Tray 1: 1,200 sheets Tray 2: 800 sheets Tray 3: 500 sheets Tray 4: 500 sheets, transparency paper 40 sheets
Warm-up time ²	Less than 240 sec.
Memory	[Copier memory] Standard 768MB Maximum 1,536MB [Printer memory] Standard 512MB Maximum 1,024MB 80GB HDD ³
Power requirements	220~240V AC, 50/60 Hz, 13A
Power consumption (max.)	2.99 kW
Dimensions (W x D x H)	1,301 x 771 x 1,518 mm
Weight	Approx. 300 kg
Features	Card shot, edge/centre erase, job build, pre-heat/auto power shut-off modes, account control (1,000 accounts), document filing

Copier

First copy time ⁴	MX-M950/MX-M1100: 3.2 sec.
Continuous copy	Max. 9,999 copies
Resolution	Scan: 600 x 300 dpi, 600 x 400 dpi, 600 x 600 dpi Print: 600 x 600 dpi
Gradation	Scan: 256 levels Print: 2 levels
Zoom range	25 to 400% (25 to 200% using DSPF) in 1% increments
Preset copy ratios	10 ratios (5 reductions and 5 enlargements)
Features	Auto paper selection (mixed/random size feeding), auto magnification selection, paper type selection, auto tray switching, rotation copy, electronic sorting, network tandem copy, book copy, margin shift, edge centre erase, dual page copy, multi-shot (4-in-1, 2-in-1), card shot, cover/transparency/tab page insertion, pamphlet copy, 2-sided copy orientation change, job build, XY zoom, B/W reverse, mirror image, duplex copy, job programme, stamps (date, page number, text, stamp), multi-page enlargement, photo repeat, tab copy, centering, proof copy, A3 full bleed, reserved copy, irregular original/paper size input, 48 job programmes

Printer

Resolution	600 x 600 dpi 1,200 x 1,200 dpi with PCL 6 and PS3
Interface	USB 2.0
Supported OS ⁷	Windows NT [®] 4.0 SP5 or later, Windows Server [®] 2003, Windows [®] 98/Me/2000/XP, Windows Vista [™] , Mac OS 9.0 to 9.2.2, Mac OS X 10.1.5, 10.2.8, 10.3.9, 10.4 to 10.4.8
PDL emulation	Standard: PCL 6/5e Option ⁸ : PS3 emulation
Available fonts	80 fonts for PCL, 136 fonts for PS3 emulation ⁸

Document Filing

Document filing capacity	Main and custom folders: 30GB, 45,000 pages ⁵ or 3,000 files Quick file folder: 10GB, 14,000 pages ⁵ or 1,000 files
Stored jobs	Standard: Copy Optional: Print, scan, fax transmission ⁶
Storage folders	Quick file folder, main folder, custom folder (max. 500 folders)
Confidential storage	Password protection

* 1 : When copying/printing same document continuously on portrait A4 plain paper in non-offset mode. Also, print mode excludes processing time.
 * 2 : At rated voltage, 25°C, 65% RH.
 * 3 : HDD capacity depends on procurement and sourcing status.
 * 4 : Portrait feeding of A4 sheets from main unit's 2nd paper tray, using document glass in Auto Exposure mode with polygon motor running.
 * 5 : Measured using Sharp's standard chart (A4 with 6% coverage). The storage capacity depends on the document contents and will be less for pages including greyscale and colour images.
 * 6 : Optional MX-FXX1 required.
 * 7 : Optional MX-PKX4 required for Mac OS and EtherTalk.
 * 8 : Optional MX-PKX4 required.
 * 9 : Based on Sharp's standard chart with approx. 700 characters (A4 portrait) at standard resolution in Super G3 mode, 33,600 bps, JBIG compression.

Network Printer (optional)

Interface	10Base-T/100Base-TX
Network protocols ⁷	TCP/IP (IPv4, IPv6), IPX/SPX (NetWare), NetBEUI, EtherTalk (AppleTalk)
Printing protocols	LPR, Raw TCP (port 9100), POP3 (e-mail printing), HTTP, Novell Printserver application with NDS and Bindery, FTP for downloading print files, EtherTalk printing, IPP
Features	Network tandem print, RIP Once/Print Many, job retention (print hold, proof print, confidential print), direct PDF/TIFF/JPEG printing, duplex print, carbon copy print, font/form download, pamphlet style, printer administration utility and status monitor, N-up (2/4/6/8/9/16), IP/MAC address filtering, binding edge, cover insertion, transparency interleave, fit to page, watermarks, form overlay, barcode font compatibility (option), tab print, secure network communications (SSL and LPD)

Network Scanner (optional)

Resolution	100, 200, 300, 400, 600 dpi
File formats	TIFF, TIFF-FX (TIFF-F), encrypted PDF, PDF, JPEG (for MX-EBX1)
Scanner utilities	Sharpdesk
Scan destinations	Scan to e-mail, desktop, FTP server, network folder (SMB), USB memory
Features	Internet fax, PC-Internet fax transmission, LDAP support, direct entry (address, subject, message), 999 one-touch dials, 500 group dials, 48 job programmes, broadcasting, slow scan, mixed size original scanning, long original scanning (max. 800 mm)

Facsimile (optional)

Compression method	MH/MR/MMR/JBIG
Communication protocol	Super G3/G3
Transmission time	Less than 3 seconds ⁹
Modem speed	33,600 bps to 2,400 bps with automatic fallback
Transmission resolution	From Standard (203.2 x 97.8 dpi) to Super Fine (406.4 x 391 dpi)
Recording size	A3 to A5
Memory	Standard 8MB
Grey scale levels	Equivalent to 256 levels
Features	Duplex reception, quick on-line transmission, 999 one-touch dials, 500 group dials, LDAP support, 48 job programmes, F-Code compatibility (confidential, relay broadcast), polling, memory transmission/reception, long original transmission (max. 800 mm), PC-Fax transmission, inbound routing to e-mail, anti-junk fax, dual page scan, mixed size original scanning, zoom transmission

- Design and specifications are subject to change without prior notice.
- Colour variations to products may occur due to printing.
- Some features require Optional items. Please consult with an authorised Sharp reseller for details.
- All information and technical details are correct as at machine release date.
- Windows and Windows Vista are either registered trademarks or trademarks of Microsoft Corporation in the United States and/or other countries. All other brand names and product names may be trademarks or registered trademarks of their respective owners.

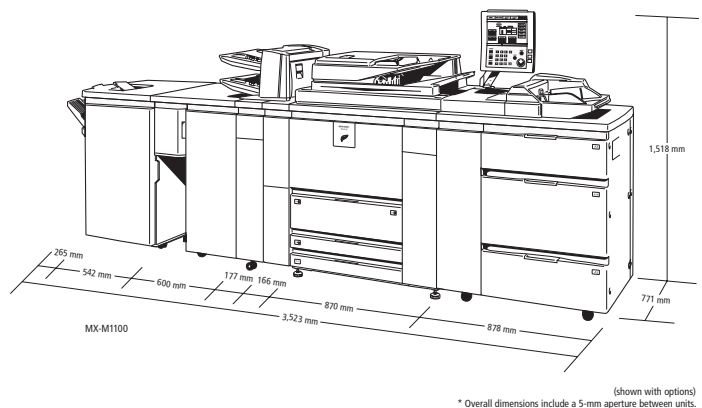

SHARP CORPORATION OF AUSTRALIA PTY LTD
 ABN 40 003 039 405
 1 Huntingwood Drive, Huntingwood NSW 2148
 PO Box 6827 Blacktown NSW 2148
 Tel: (02) 9830 4600 Fax: (02) 9672 1208
 www.sharp.net.au

Distributed by:

SHARP

Simply the best.

Australian Government Endorsed Supplier
 Supporting Australian Business